

# September Light

by Lida Enche

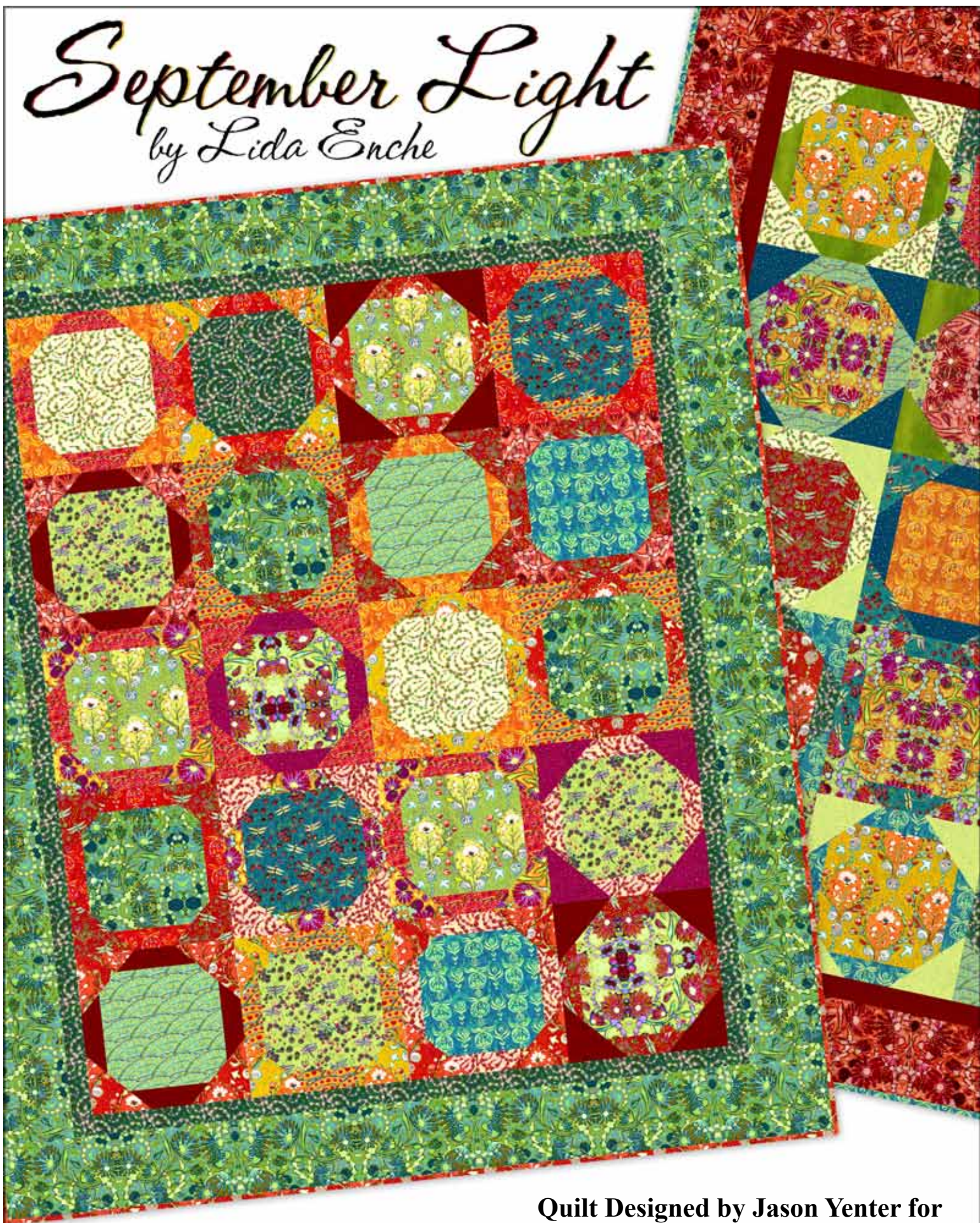

Quilt Designed by Jason Yenter for  
**In The Beginning** *fabrics*

**FINISHED BLOCK SIZE: 16" x 16"**

**FINISHED QUILT SIZE: 84½" x 100½"**

- A separate materials list is given for each of the two quilts.
- Yardages are based on 40" fabric width.

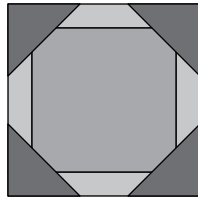

### **Materials: Red Quilt**

- ¾ yd. Red Spots (8LEA1) for inner border
- 3⅞ yds. Red Daisy (1LEA1) for outer border and blocks
- 1½ yds. Blue Floral Heart (4LEA3) for binding and blocks
- ½ yd. Magenta/Gold Daisy (1LEA2) for blocks
- ½ yd. Lavender/Green Daisy (1LEA3) for blocks
- ⅝ yd. Teal Daisy (1LEA4) for blocks
- ½ yd. Red Floral/Bird Medallion (2LEA1) for blocks
- ½ yd. Orange Floral/Bird Medallion (2LEA2) for blocks
- ⅔ yd. Green Floral/Bird Medallion (2LEA3) for blocks
- ½ yd. Red Dragonflies (3LEA1) for blocks
- ⅔ yd. Green Dragonflies (3LEA2) for blocks
- ⅔ yd. Blue Dragonflies (3LEA3) for blocks
- ½ yd. Orange Floral Heart (4LEA2) for blocks
- ½ yd. Magenta/Red Berries (5LEA1) for blocks
- ½ yd. Red/Gold Berries (5LEA2) for blocks
- ⅝ yd. Green/Blue Berries (5LEA4) for blocks
- ½ yd. Red Floral Swirl (6LEA1) for blocks
- ⅝ yd. Light Green Floral Swirl (6LEA2) for blocks
- ⅞ yd. Dark Green Floral Swirl (6LEA3) for blocks
- ⅔ yd. Green Colorwash (7LEA4) for blocks
- ⅞ yd. Blue/Green Spots (8LEA3) for blocks
- ⅞ yd. Green/Teal Spots (8LEA5) for blocks
- 8¼ yds. for backing (widthwise seams)

### **Materials: Green Quilt**

- 1⅞ yds. Dark Green Floral Swirl (6LEA3) for inner border and blocks
- 3⅞ yds. Teal Daisy (1LEA4) for outer border and blocks
- 1⅝ yds. Red Floral/Bird Medallion (2LEA1) for binding and blocks
- ½ yd. Red Daisy (1LEA1) for blocks
- ⅔ yd. Magenta/Gold Daisy (1LEA2) for blocks
- ½ yd. Lavender/Green Daisy (1LEA3) for blocks
- ⅔ yd. Orange Floral/Bird Medallion (2LEA2) for blocks
- ½ yd. Green Floral/Bird Medallion (2LEA3) for blocks
- 1 yd. Red Dragonflies (3LEA1) for blocks
- ½ yd. Green Dragonflies (3LEA2) for blocks
- ½ yd. Blue Dragonflies (3LEA3) for blocks
- ⅝ yd. Red Floral Heart (4LEA1) for blocks
- ⅔ yd. Orange Floral Heart (4LEA2) for blocks
- ½ yd. Blue Floral Heart (4LEA3) for blocks
- ¾ yd. Magenta/Red Berries (5LEA1) for blocks
- ⅞ yd. Red/Gold Berries (5LEA2) for blocks
- ½ yd. Green/Blue Berries (5LEA4) for blocks
- ⅝ yd. Red Floral Swirl (6LEA1) for blocks
- ½ yd. Light Green Floral Swirl (6LEA2) for blocks
- ⅞ yd. Red Spots (8LEA1) for blocks
- ½ yd. Green/Magenta Spots (8LEA4) for blocks
- 8¼ yds. for backing (widthwise seams)

### **Cutting**

*The cutting instructions are generalized for both quilts. Cut strips across width of fabric, unless otherwise instructed. IMPORTANT NOTE: Cut outer border, inner border, and binding strips first, as listed below. Leftovers from those prints can then be used in the blocks.*

#### **Border and Binding Strips**

*From Red Spots (Red Quilt) -OR- Dark Green Floral Swirl (Green Quilt), cut:*

- 8 strips, 2½" x 40", for inner border (Note: If you are making the Red Quilt, you won't need leftovers of the Red Spots print for your blocks.)

*From Red Daisy (Red Quilt) -OR- Teal Daisy (Green Quilt), cut:*

- 4 lengthwise strips, 8½" x 88", for outer border

*From Blue Floral Heart (Red Quilt) -OR- Red Floral/Bird Medallion (Green Quilt), cut:*

- 10 strips, 2½" x 40", for double-fold binding

## Block Pieces

As you begin to cut pieces for your blocks, refer to the sample quilts for fabric-placement ideas. Use assorted prints for the blocks (including fabrics leftover after cutting border and binding pieces, as well as all of the prints in the materials list with the exception of the backing fabric).

**For each block, use three different prints, and cut:**

From first print:

- 1 square,  $12\frac{1}{2}$ " x  $12\frac{1}{2}$ ", for block center

From second print:

- 2 rectangles,  $2\frac{1}{2}$ " x  $16\frac{1}{2}$ "
- 2 rectangles,  $2\frac{1}{2}$ " x  $12\frac{1}{2}$ "

From third print:

- 4 squares,  $6\frac{1}{2}$ " x  $6\frac{1}{2}$ ", for block corners (A stitch-and-flip technique will be used.)

**Cut pieces for a total of 20 blocks.**

## Assembly

All seams  $\frac{1}{4}$ ". Press seams in direction of arrows unless otherwise instructed. Assembly instructions are the same for both quilts. Refer to photographs for fabric placement.

- Using one  $12\frac{1}{2}$ " square, two  $2\frac{1}{2}$ " x  $12\frac{1}{2}$ " rectangles, and two  $2\frac{1}{2}$ " x  $16\frac{1}{2}$ " rectangles, assemble a square unit as shown. Repeat to make a total of 20 units.

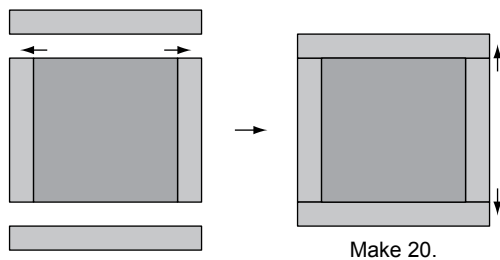

- Using a pencil and ruler, draw a diagonal line, from corner to corner, on the wrong side of the 80 assorted-print  $6\frac{1}{2}$ " squares.

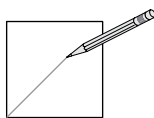

- With right sides together, place one of the marked  $6\frac{1}{2}$ " squares in one corner of a square unit (made in Step 1), being careful to orient it as shown. Sew on the drawn line. Trim as shown, leaving a  $\frac{1}{4}$ " seam allowance. Press seam toward triangle. Repeat technique on remaining three corners of square unit. Then repeat entire step to make a total of 20 blocks.

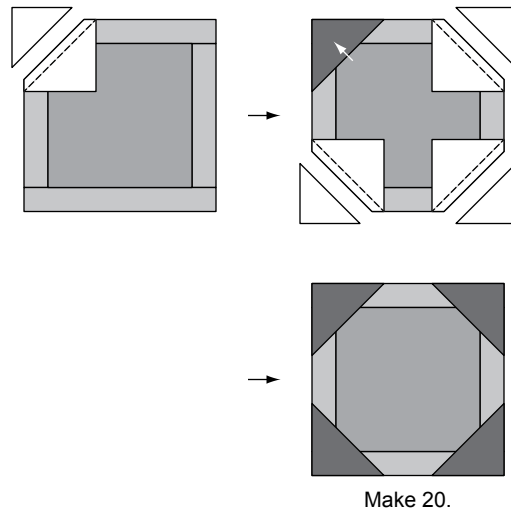

- Sew 4 blocks together in a row as shown. Repeat to make a total of 5 rows. Press seams in opposite directions from row to row.

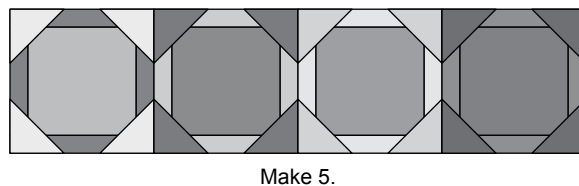

- Sew rows together as shown in the Quilt Assembly Diagram on back page. Press seams in one direction.

## Borders

- Sew the 8 inner border strips together, end-to-end, to make one long strip. Press seams open.
- Measure length of quilt top through center. From the long strip, cut 2 inner border strips to this measurement, and sew to sides of quilt as shown in the Quilt Assembly Diagram. Press seams toward inner borders.
- Measure width of quilt top, including borders just added, through center. From the long strip, cut 2 inner border strips to this measurement, and sew to top and bottom of quilt. Press seams toward inner borders.

4. Measure length of quilt top through center. Trim 2 outer border strips to this measurement, and sew to sides of quilt. Press seams toward outer borders.
5. Measure width of quilt top, including borders just added, through center. Trim remaining 2 outer border strips to this measurement, and sew to top and bottom of quilt. Press seams toward outer borders.

### **Finishing**

Layer quilt top, batting, and backing. Quilt as desired. Bind. Don't forget to sign and date your finished quilt.

In The Beginning Fabrics ©2011  
8057 16th Ave. NE • Seattle, WA 98115  
[www.inthebeginningfabrics.com](http://www.inthebeginningfabrics.com)

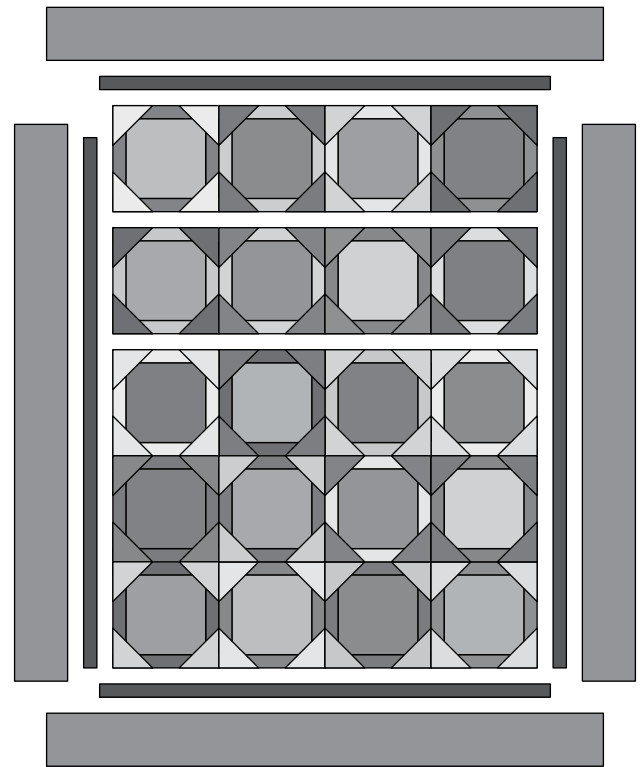

Quilt Assembly Diagram

